

WC09 - Replacing Clutch Pedal Switch (Workshop Campaign)

Vehicle Type: **911 Carrera (997)/911 Carrera S (997)**
911 Sport Classic (997)/911 Carrera GTS (997)
911 Carrera 4 (997)/911 Carrera 4S (997)
911 Targa 4 (997)/911 Targa 4S (997)
911 Turbo (997)
911 GT3 (997)/911 GT3 RS (997)/911 GT2 (997)/911 GT2 RS (997)

Model Year: **As of 2008 up to 2011**

Equipment: 6-speed manual transmission (I-no. 480)

Concerns: **Clutch pedal switch**

Information: This is to inform you of a voluntary Workshop Campaign on the above-mentioned vehicles. There is the possibility that plastic particles may be deposited on the contacts of the clutch pedal switch on the affected vehicles over their service life, causing electric malfunctions of the switch. As a result, the message "Depress clutch pedal" may be displayed in the instrument cluster when you try to start the engine, although the clutch pedal is already pressed, and the engine only starts after several attempts.

Action Required: Replace clutch pedal switch.

Affected Vehicles: The VIN(s) can be checked by using PIWIS Vehicle Information link to verify if the campaign affects the vehicle. This Campaign is scope specific to the VIN! Failure to verify in PIWIS may result in an improper repair.

Note: **PLEASE DO NOT ORDER PARTS FOR THIS SERVICE CAMPAIGN. REQUIRED PARTS WILL BE AUTOMATICALLY ALLOCATED TO YOUR DEALERSHIP.**

Parts Info: 000.043.207.86 ⇒ Clutch pedal switch 1 ea.

Materials: 000.043.206.17 ⇒ Renocal grease 10g tube
(approx. 0.5 grams of grease required per vehicle)

Tools: Screw insert bit Torx 10 or crosshead PZ1

Work Procedure: See Attachment "A".

Claim Submission: See Attachment "B".

Attachment "A": **Work Procedure**

- 1 Switch off ignition and remove ignition key.
- 2 Place a protective mat over the door entry area as far as the footwell on the driver's side.
- 3 Remove clutch pedal switch.



Information

Clutch pedal switch shown in Figure 1 viewed from the perspective "lying in the driver's footwell under the dashboard, looking up".

- 3.1 Carefully pull both connectors ⇒ *Figure 1 -1-* off the clutch pedal switch ⇒ *Figure 1 -2-* (⇒ *Figure 1 -arrow-*).

Note colour arrangement of the connectors.

- 3.2 Unscrew fastening screw ⇒ *Figure 2 -1-* on the clutch pedal switch ⇒ *Figure 2 -2-* and remove the clutch pedal switch ⇒ *Figure 2 -arrow-*.

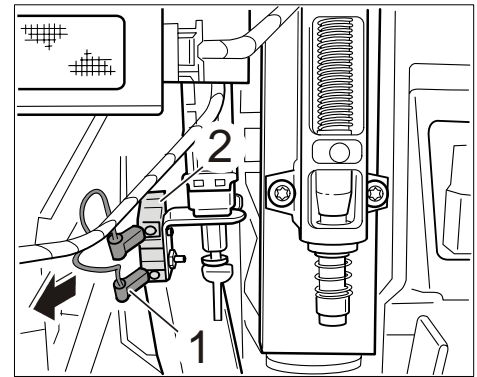

Figure 1

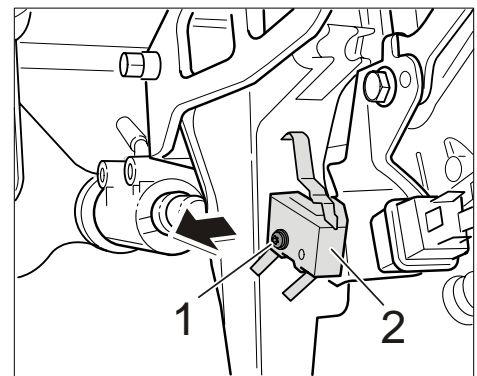

Figure 2

- 4 **Install new** clutch pedal switch, Part No. **000.043.207.86.**
 - 4.1 Coat the contact surface on the clutch pedal switch ⇒ *Figure 3-1-* as shown in ⇒ *Figure 3* with Renocal, Part No. 000.043.206.17.
 - 4.2 Guide the clutch pedal switch ⇒ *Figure 3-1-* with the tubular rivet into the bore on the holder ⇒ *Figure 3-arrow-*.
 - 4.3 Screw fastening screw ⇒ *Figure 3-2-* in slightly so that the clutch pedal switch ⇒ *Figure 3-1-* can still be moved.
 - 4.4 Press the clutch pedal switch ⇒ *Figure 3-1-down* as far as it will go in the slot and tighten the fastening screw ⇒ *Figure 3-2-*.
 - 4.5 Carefully plug in both connectors ⇒ *Figure 4-1-* on the clutch pedal switch ⇒ *Figure 4-2-* (⇒ *Figure 4-arrow-*).
- 5 Remove protective mat.
- 6 Check the function of the clutch pedal switch.
 - 6.1 Insert ignition key and switch on the ignition.
 - 6.2 Actuate the clutch pedal fully and start the engine.

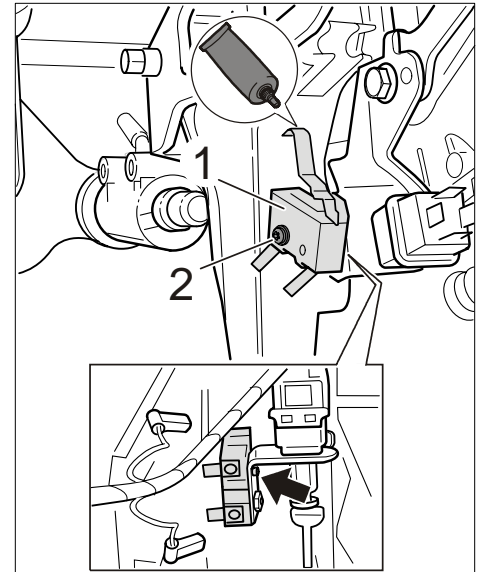

Figure 3

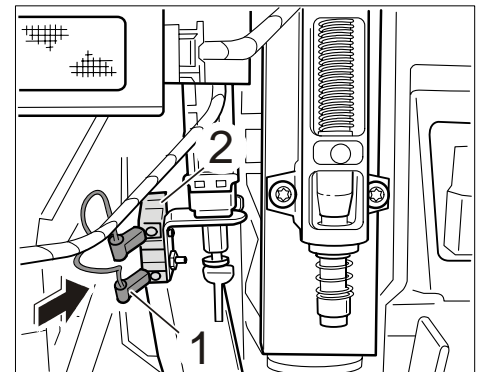

Figure 4



Information

If the engine will not start and the message “Depress clutch pedal” is displayed in the instrument cluster, loosen the fastening screw on the clutch pedal switch again and press the clutch pedal switch slightly towards the upper stop in the slot.

Then re-tighten the fastening screw and check the function of the clutch pedal switch again.

- 7 Enter the workshop campaign in the Warranty and Maintenance booklet.

Attachment "B": **Claim Submission-** Workshop Campaign WC09
 Warranty claims should be submitted via WWS/PQIS.
 Open campaigns may be checked by using either the PIWIS Vehicle Information system or through PQIS Job Creation.
 Labor, parts, and sublet will be automatically inserted when Technician is selected in WWS/PQIS.

Working time:

Replacing clutch pedal switch

Labor time: **10 TU****Parts required:**

000.043.207.86	Clutch pedal switch	1 ea.
000.043.206.17	Grease	0.05 ea. (i.e. 0.5 grams of grease)

⇒ **Damage code WC09 066 000 2**

Important Notice: Porsche Cars N.A Technical Bulletins are intended for use by professional technicians, not a "Do-it-yourselfer." They are written to inform these technicians of conditions that may occur on some vehicles, or to provide information that could assist in the proper service of a vehicle. Special tools may be required to perform certain operations identified in these bulletins. Use of tools and procedures other than those recommended in these bulletins may be detrimental to the safe operation of your vehicle. Properly trained technicians have the equipment, tools, safety instructions and know-how to do a job properly and safely. If a condition is described, do not assume that the bulletin applies to your vehicle, or that your vehicle will have that condition. See your Porsche Dealer for information on whether your vehicle may benefit from the information. Part numbers listed in these bulletins are for reference only. Always check with your authorized Porsche dealer to verify correct part numbers.

© Porsche Cars North America, Inc.

Dealership	Service Manager	_____	Shop Foreman	_____	Service Technician	_____	_____	_____	_____
Distribution	Asst. Manager	_____	Warranty Admin.	_____	Service Technician	_____	_____	_____	_____
Routing									

Dr. Ing. h.c. F. Porsche AG is the owner of numerous trademarks, both registered and unregistered, including without limitation the Porsche Crest®, Porsche®, Boxster®, Carrera®, Cayenne®, Cayman™, Panamera®, Tiptronic®, VarioCam®, PCM®, 911®, 4S®, FOUR, UNCOMPROMISED.® and the model numbers and distinctive shapes of Porsche's automobiles such as, the federally registered 911 and Boxster automobiles. The third party trademarks contained herein are the properties of their respective owners. Some vehicles may be shown with non-U.S. equipment. Porsche recommends seat belt usage and observance of traffic laws at all times.

Printed in the USA